

# V-TUF<sup>®</sup>



## RAPIDHB240-21

## RAPIDHB110-21

V-TUF RAPID HOT BOX

OPERATOR MANUAL



Please read this manual before using the HB240-21 & HB110-21

## GLOSSARY

In the present list they are rechon up the terminologies and abbreviation descriptions most commonly used on the present manual.

H.P	High pressure	Rif.	Reference
L.P	Low pressure	V	Volt
min.	Minimum	Ah	Ampere
max.	Maximum	Hz	Hertz
1'	Minutes	kW	Kilowatt
h	hour	°C	Degrees centigrade
H	Height	kg	Kilogram
L	Length	CO	Carbon dioxide
Fig.	Figure	l/h	Litres/hour
Pag.	Page	Mono	Monophase
Sez.	Section	Tri	Triphase
Automat.	Automatically	TS	Total Stop
Man.	Manual	CEE	European Economic Community

## LEGENDA

FLUXOSTATH     Device suitable for take off the flux of a liquid

## SUMMARY

1	INTRODUCTION	Pag. 1	21	TRANSPORT-HOISTING	Pag. 17
2	GENERAL DIRECTIONS	Pag. 1		DISPLACEMENT	
3	IMPORTANT RECOMMENDATIONS	Pag. 2	22	STORING	Pag. 17
4	TECHNICAL FEATURES	Pag. 3	23	WARRANTY CONDITIONS	Pag. 18
5	TECHNICAL DATAS	Pag. 4	24	ACCESSORIES	Pag. 19
6	DIMENSIONS	Pag. 5	25	SCRAPPING	Pag. 20
7	MACHINE DESCRIPTION	Pag. 5			
8	IDENTIFICATION DATA	Pag. 6			
9	CONTROLS	Pag. 7			
10	ADHESIVES	Pag. 7			
11	OUTFIT	Pag. 7			
12	SAFETY STANDARDS	Pag. 8			
13	IMPROPER USE	Pag. 8			
14	WRONG USE	Pag. 8			
15	PRECAUTIONS	Pag. 10			
16	INSTALLATION	Pag. 11			
17	USE	Pag. 11			
18	MAINTENANCE	Pag. 13			
19	FAULT-CAUSE-REMEDIES	Pag. 15			
20	SYSTEM PLANS	Pag. 16			

## **TECHNICAL FEATURES**

---

Fire proof feeding cable.

Fiber-glass reinforced incoming sheathing cable.

Equipotential circuit.

Plastic switchboard.

Painted steel frame.

Cover in plastic material fixed by means of screw.

Noise level below the limits according to the directives.

Boiler V1 type with double steel coil at high thermal conductivity, upper, lower head and vane in stainless steel, bottom made of thick refractory cement, embedded in the casing .

Quick coupling assembled on the water inlet and outlet.

Two rigid type rubber wheels.

Two pivotant type rubber wheel (one with parking brake).

High tension transformer.

Safety valve.

No return valve.

Fluxostath.

Termostath.

Painted steel gasoil tank.

The machine is constructed with riciclables materials.

The mobile boiler can work in joining with every cold water high pressure washer to obtain warm water.

**TECHNICAL DATAS**

---

MODEL	200
MAX. PRESSURE	200 bar
MAX POWER	450 W
MAX. FLOW	900 l/h
MAX. WATER FEEDING PRESS.	4 bar
WATER TEMPERATURE	30/150 °C
THERMAL POWER	53.000 K.cal. /h
POWER SUPPLY	230 V monophase
WEIGHT	70 kg
GASOIL TANK CAPACITY	11 litres
EXHAUST SMOKE	less than 2 on the "Shell Bacharach" scale
CO RELEASE	les than 0,04% of the volume
FREQUENCY	50 Hz

**60 Hz version, upon request**

**MAX BEARING VALUES OF THE ACOUSTIC LEVELS**

ACOUSTIC PRESSURE LEVEL IN ATMOSPHERE

ACOUSTIC POWER LEVEL

LEVEL OF THE ACOUSTIC PRESSURE AT THE  
OPERATING PLACELess than the limits according to the  
EEC directives

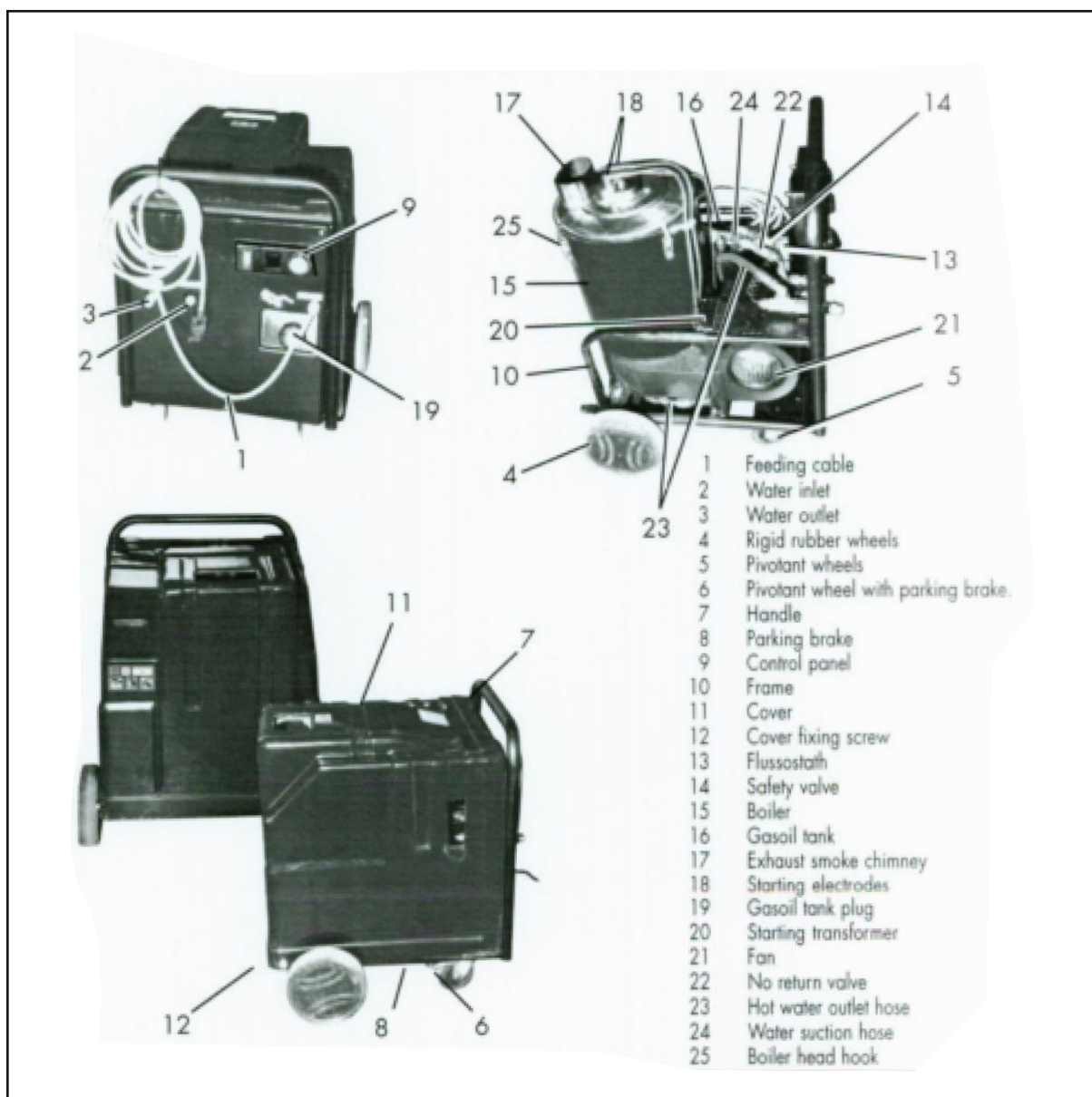

<b>ITEM</b>	<b>CODE</b>	<b>Description</b>	<b>QTY</b>
1	0000	Feeding Cable	1
2	0000	Water Inlet	1
3	0000	Water Outlet	1
4	0000	Rigid rubber wheels	1
5	0000	Pivotant wheels	1
6	0000	Pivotant wheels with parking brake	1
7	0000	Handle	1
8	0000	Parking brake	1
9	0000	Control panel	1
10	0000	Frame	1
11	0000	Cover	2
12	0000	Cover fixing screw	2
13	0000	Flussostath	2
14	0000	Safety valve	3
15	0000	Boiler	3
16	0000	Gasoil Tank	3
17	0000	Exhaust smoke chimney	3
18	0000	Starting electrodes	1
19	0000	Gasoil tank plug	1
20	0000	Starting transformer	4
21	0000	Fan	4
22	0000	No return valve	1
23	0000	Hot water outlet hose	1
24	0000	Water suction hose	2
25	0000	Boiler head hook	2

## CONTROLS

---



- 1 ON/OFF switch
- 2 Thermostat adjusting knob

## PRECAUTIONS

---

Before starting the machine, make sure that the inlet water supply is properly connected (1 bar min., 4 bar max.), running dry, can damage the pump.

Always check that the exhaust smoke chimney and the air intakes are not obstructed.

As a safety measure for the worker and for the machine same, do not modify the H.P. washer without the manufacturer permit in writing.

If You detect find a damage, before starting a working, immediately contact Your Dealer.

When using the H.P. cleaner, never cover it; however if You think that is necessary to protect it, do it letting the air through so as to cool down the motor.

Switch the machine off, during longer idle periods (more than 15/20 minutes), and unload the pressure in the machine by pulling the spraying gun trigger.

For working breaks of one hour or more, it is necessary to remove the electrical plug from the electrical socket.

The maintenance works, requires the intervention of semi-skilled personnel that are also acquainted with this instructions manual and all the same well-informed about the safety general regulations as about the machine's specific safety systems.

For repair, special maintenance operations or for the setting up of the machine, apply to the Customer Service Centre or to the authorized technicians only.

## INSTALLATION

### OPERATORS IN CHARGE

The machine installation will be carry out only by skilled technicians with the care and responsibility of the user.

Connect the suction hose to the inlet coupling.

Connect the outlet hose to the outlet coupling.

Connect the other end of the suction hose to the water tap.

Check that the electric plug has all the required characteristics and the proper differential protection than, connect if into the electrical socket.

**NOTE:** if is possible, do not use electrical extensions.



**H<sub>2</sub>O outlet**

**H<sub>2</sub>O inlet**



**WARNING:** the electrical feeding network must be equipped with an high sensibility differential switch with an interference thresold id equal to 30 mA.

The machine must be earthed at a contact voltage resistant value not over 25 V.

The machine must be installed so that the pipings cannot be damaged by people or things.

The machine should be placed out of passage ways and in order to avoid mechanical stress and damages.

## USE

### CHECKS BEFORE USE

Before the use, check that all the parts was fitted up and that the installation was checked by skilled personnel.

Check that are gasoil in the apposite tank, if not, fill up.

Turn on the water lap.

Check that the thermostat is in "0" °C position.

Start the machine acting on the apposite (ON/OFF) burner switch and wait for 30 sec. to obtain the filling of the gasoil pump, act on the thermostat knob and put the temperature selector at 90° C for almost 30 sec. than, select tha water working temperature acting on the same knob.

When the request temperature is reached, the burner automatically stop and start again every time the temperature reachees.

At the end of the work, put the thermostat knob at ("0") 0° C position and wait for the water to be cold.

Act on the (ON/OFF) burner switch to stop the machine then, close the water tap.

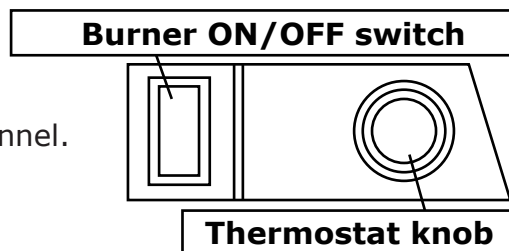



## USE

---

### USE IN ENCLOSED AREAS

In case the machine is placed in an enclosed area,  
You have to install the chimney adapter our code: 5000030.

We suggest the use of a chimney as illustrated in the picture.



WARNING: the chimney (2) diameter (Z) should not be inferior than the adapter (1).

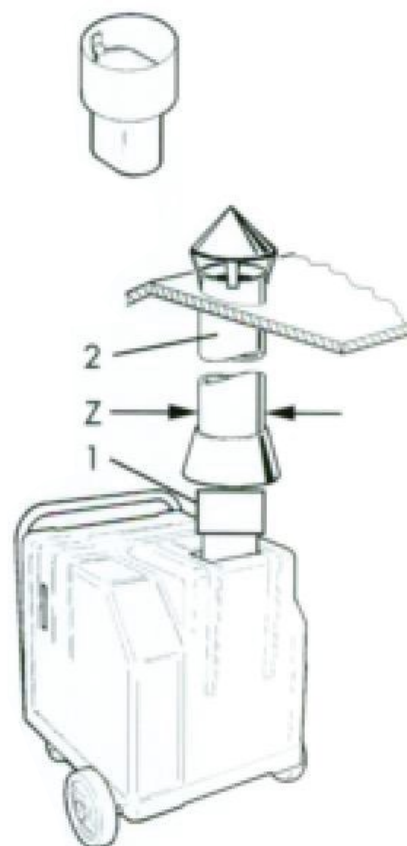

### USE IN WINDY PLACE

In case the machine is placed in a windy place, You have to install the chimney adapter our code: 5000030.

This precautionary measure can avoid damages to Your machine.



## V-TUF STEAM OPERATION WITH HOT BOX

---

With the aid of the V-TUF Super-heated steam performance kit. You can customise your "hotbox" for many demanding & specialised cleaning processes, including historical restoration & renovation projects.

### SUPER HEATED STEAM PERFORMANCE KIT:

---

Set up the **PRESSURE GAUGE 0 to 300BAR CALIBRATING KIT MSQ - C6.030KIT** below on the cold side of the HOT BOX. Remove the gauge kit once calibration.



To select the ultimate pressure suited to the surface you are cleaning, and make sure that you have the correct nozzle size (see below) to suit that pressure.

- Nozzle size: 09 - Pressure: 30 BAR**
- Nozzle size: 08 - Pressure: 40 BAR**
- Nozzle size: 07 - Pressure: 50 BAR**
- Nozzle size: 065 - Pressure: 60 BAR**
- Nozzle size: 06 - Pressure: 70 BAR**
- Nozzle size: 05 - Pressure: 100 BAR**
- Nozzle size: 04 - Pressure: 145 BAR**

Remember: Please select the best jet spray angle too (0 degree; 15 degrees; 25 degrees; 40 degrees).

- 0 degree jets:** <https://www.v-tuf.co.uk/spares-accessories/triggers-lances-nozzles/nozzles-holders/fan-nozzles/00-pencil-jet-nozzle>
- 15 degree jets:** <https://www.v-tuf.co.uk/spares-accessories/triggers-lances-nozzles/nozzles-holders/fan-nozzles/150-fan-nozzle>
- 25 degree jets:** <https://www.v-tuf.co.uk/spares-accessories/triggers-lances-nozzles/nozzles-holders/fan-nozzles/250-fan-nozzle>
- 40 degree jets:** <https://www.v-tuf.co.uk/spares-accessories/triggers-lances-nozzles/nozzles-holders/fan-nozzles/400-fan-nozzle>

These nozzles are calibrated with the standard hot box fuel injector size of 1.35 80H

---

To maintain efficient and effective cleaning above 100 deg C with your V-TUF HOTBOX there are certain very important settings that must be in place:

1. For optimal cleaning effectiveness, turn the pressure adjustment knob (anti-clockwise – to lower pressure) on your V-TUF pressure washer.
2. Calibrate the pressure (before switching the HOT BOX on) to the correct nozzle size as shown in the list on the previous page.



**Picture 1**

2. Please the jet into the end of the spray lance and then check your calibration on cold. Once you are happy with this then turn the thermostat of your HOTBOX on highest temperature (clock-wise – see below)



**Picture 2**

Important points:

1. Run machine on this setting and you will notice the hot water will start steaming.
2. Proceed with cleaning.
3. Please note when the unit is very hot, the trigger can only be closed off for very short periods.
4. If you wish to take a break – you must turn the thermostat knob (picture 2) anti-clockwise to 0 degC and run the water cool. **Do this every time!**

## MAINTENANCE

Maintain in efficiency the equipment it means to ensure more reliability and a longer life; please follow simple check on a regular basis.



### SAFETY RULES

Do not consent intervention on the machine at not authorized personnel.

Do not carry out any intervention without preventive authorization.

Before every check and/or maintenance work, check that the machine



Do not put the limbs into the openings of the machine parts without the aid of suitable guards.

Do not align the holes with the fingers but only using the suitable centering foils.

Never use gasoline, solvents or other flammable liquid to clean; instead apply to the commercialized detergents, authorized, unflammables and un toxic.

Using compressed air for clean or dry parts of the machine, protect the eyes with goggles equipped with side guards and limit the air working pressure at max. 1,9 bar.



Every day keep clean and in good order the machine.

Immediately replace each notice, warning or instruction plate that is not readable or missing



**WARNING:** a poorly adjustment of the burner, increases the fuel consumption and causes environmental pollution.

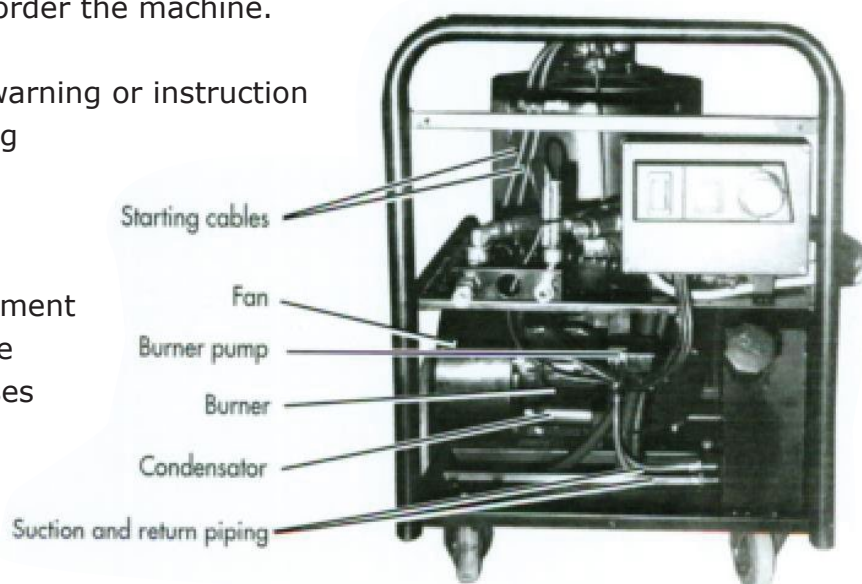

**WARNING:** if the machine remain for a long time idle, before using it for any cleaning operation, we suggest to let the water flow in the coil for some time, fill it comes out clean.

## BURNER MAINTENANCE

The burner installed on our high pressure cleaner, runs only with gasoil. Periodically check and clean the filters and the fuel nozzle, we recommend the replacement of the same every 400 working hours.

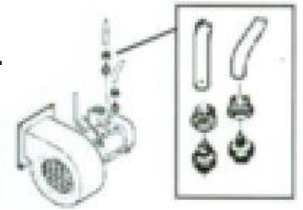

## BODY AND TANK WORK MAINTENANCE

Wash the machine only with neutral surface-active products and water in order to eliminate corrosive agents (such as salt, sand, etc.); accurately dry so as to thoroughly eliminate any patches of water.

If trace of dirt persist, we recommend the use of specific products following the instructions provided by the manufacturer.



**WARNING:** DO NOT USE products containing aromatic solvents, methanol or hydrocarbon.

## HYDRAULIC SYSTEM

Periodically check that all the system parts are correctly tight and that are not leakages.

## COIL

If the coil is covered with soot, You should check the burner at the Customer Service Centre.



## AIR FLOW ADJUSTMENT

On 60 Hz models is installed an air flow adjusting blade; this device placed between the fan and the boiler is adjusted by the manufacturer but acting on the apposite nut, the slope will be changed for allow a small or a greater air flow.

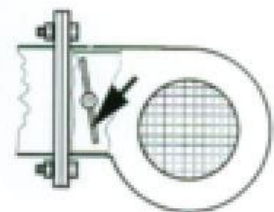

## ELECTRODES SETTING

To obtain the best performances of the machine, check that the starting electrodes are always placed as shows in picture.

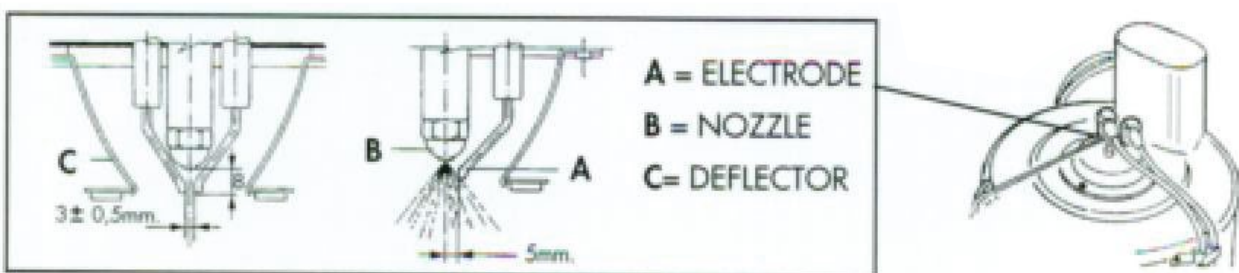

**WARNING:** for repair, special maintenance operations or for setting up of the machine, apply to the Customer Service Centre or to the authorized technicians only.



<p>The water does not reach working temperature.</p>	<p>Damaged thermostat. Thermostat adjusted too low.</p> <p>Scale in the hydraulic system.</p> <p>Sooted boiler.</p>	<p>Replace. Place the thermostat at the required temperature. Contact the Maintenance Service. Contact the maintenance Service.</p>
<p>The boiler is smoking</p>	<p>Water in the gasoil tank.</p> <p>Incorrect gasoil pressure.</p> <p>Electrodes improperly positioned.</p> <p>Fuel nozzle dirty. Fuel nozzle worn out. Heating coil blocked by soot. Gasoil pump dirty.</p> <p>Gasoil solenoid valve not operating.</p>	<p>Completely drain the gasoil tank than, fill up with clean gasoil. Turn the adjusting screw until obtaining aprox. 10 bar; contact the Maintenance Service. Adjust the distance between the electrodes; contact the Maintenance Service. Clean the fuel nozzle. Replace the fuel nozzle. Clean the heating coil. Disassemble the pump and clean the filter; contact the Maintenance Service. Replace the solenoid valve.</p>
<p>The burner cut out during operation</p>	<p>Gasoil tank empty Water in the gasoil tank.</p> <p>Fluxostath damaged. Starting transformer damaged. Rotation of the starting electrodes.</p> <p>Gasoil nozzle dirty. Gasoil nozzle damaged. Gasoil pump damaged. Gasoil solenoid valve damaged.</p>	<p>Fil up the gasoil tank. Completely drain the gasoil tank and fill up with clean gasoil Replace the fluxostath. Replace the transformer. Set the electrodes back to their proper position; contact the Maintenance Service. Clean the nozzle. Replace the nozzle. Replace the gasoil pump. Replace the gasoil solenoid valve.</p>
<p>The motor does not start</p>	<p>No current.</p>	<p>Check if the plug is in the socket and if there is current in the network.</p>

## SYSTEM PLANS

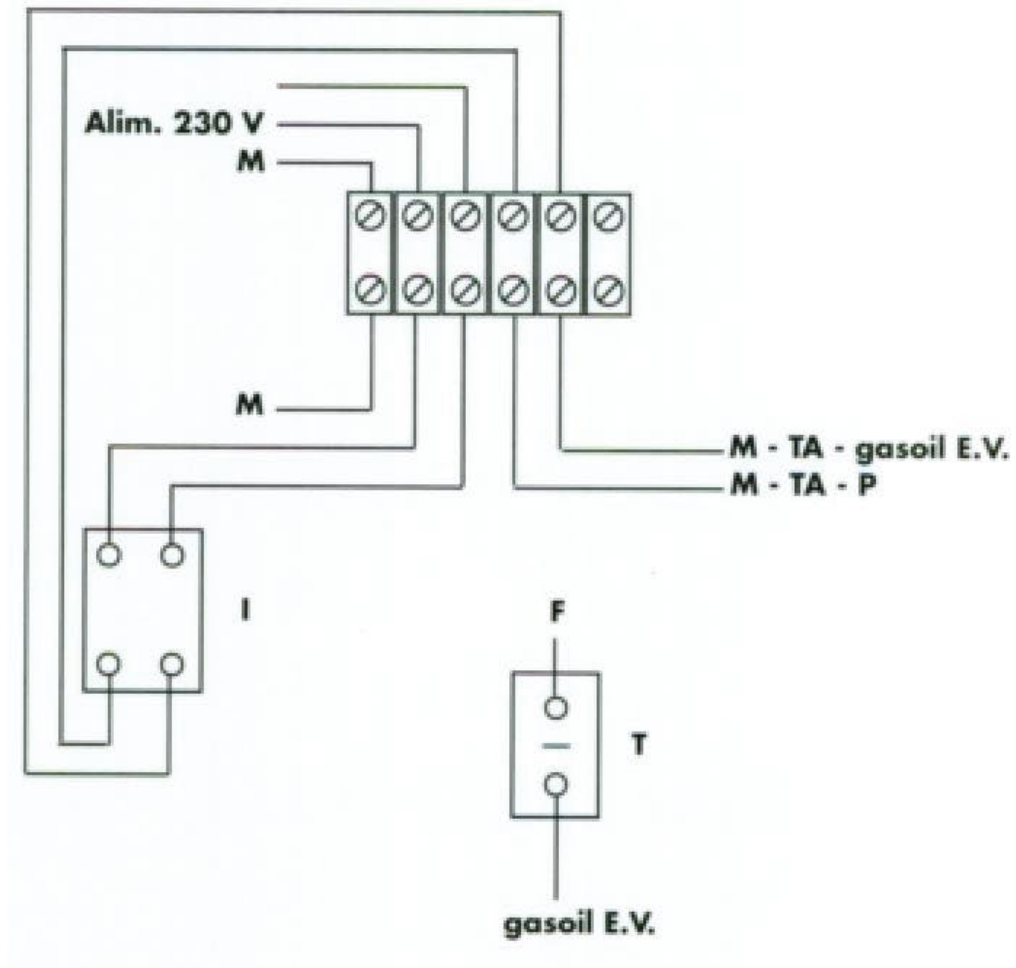
### WIRING DIAGRAM



<b>I</b>	Switch
<b>MP</b>	Burner motor
<b>TA</b>	Transformer
<b>F</b>	Fluxostath
<b>E.V.</b>	Gasoil solenoid valve
<b>T</b>	Thermostat
<b>M</b>	Ground

<b>V-TUF</b> Great Britain		  <b>IPX5</b>	 <b>55 dB</b>
Model / Modello	<b>MOBILE BOILER</b>		
Type / Tipo	<b>V-TUF RAPID HB240-21</b>		
Serial Nr. / Numero di serie	<b>058135</b>		
Lot production / Lotto	<b>06/19</b>		
Working pressure Pressione d'esercizio	<b>58-3625</b>	<b>psi</b>	
	<b>4-250</b>	<b>bar</b>	
Feed press. Min. / Max. Press. di Aliment. Min. / Max	<b>58 / 145</b>	<b>psi</b>	
	<b>4 / 10</b>	<b>bar</b>	
Max feeding temp. Temp. Max Aliment.	<b>86</b>	<b>°F</b>	
	<b>30</b>	<b>°C</b>	
Water output max. temp. Temp. Max Uscita Acqua	<b>284</b>	<b>°F</b>	
	<b>140</b>	<b>°C</b>	
Motor horsepower/Potenza effett.	<b>0,5</b>	<b>Kw</b>	
Numero di Giri/ R.P.M.	<b>2800</b>	<b>Rpm</b>	
Frequency/Frequenza	<b>50</b>	<b>Hz</b>	
Voltage / Tensione	<b>230V 1~+T</b>		
Max pressure Pressione Massima	<b>3625</b>	<b>psi</b>	
	<b>250</b>	<b>bar</b>	
Delivery Portata	<b>5,55</b>	<b>Gpm</b>	
	<b>21</b>	<b>l/min.</b>	
Boiler Output/Potenza Caldaia	<b>58</b>	<b>Kw/h</b>	

Our Company reserves the right to introduce at any time, eventual changes for technical or commercial reasons, therefore informations, descriptions and illustrations contained in this publication, are updated until their approval for the printing.

**WARNING:** the graphic illustration of the part, can be different from the detail mounted on the machine, only the code number on the spare parts catalogue, determinates the spare part validity.



**V-TUF<sup>®</sup>**

[www.V-TUF.COM](http://www.V-TUF.COM)