

MAXI 80

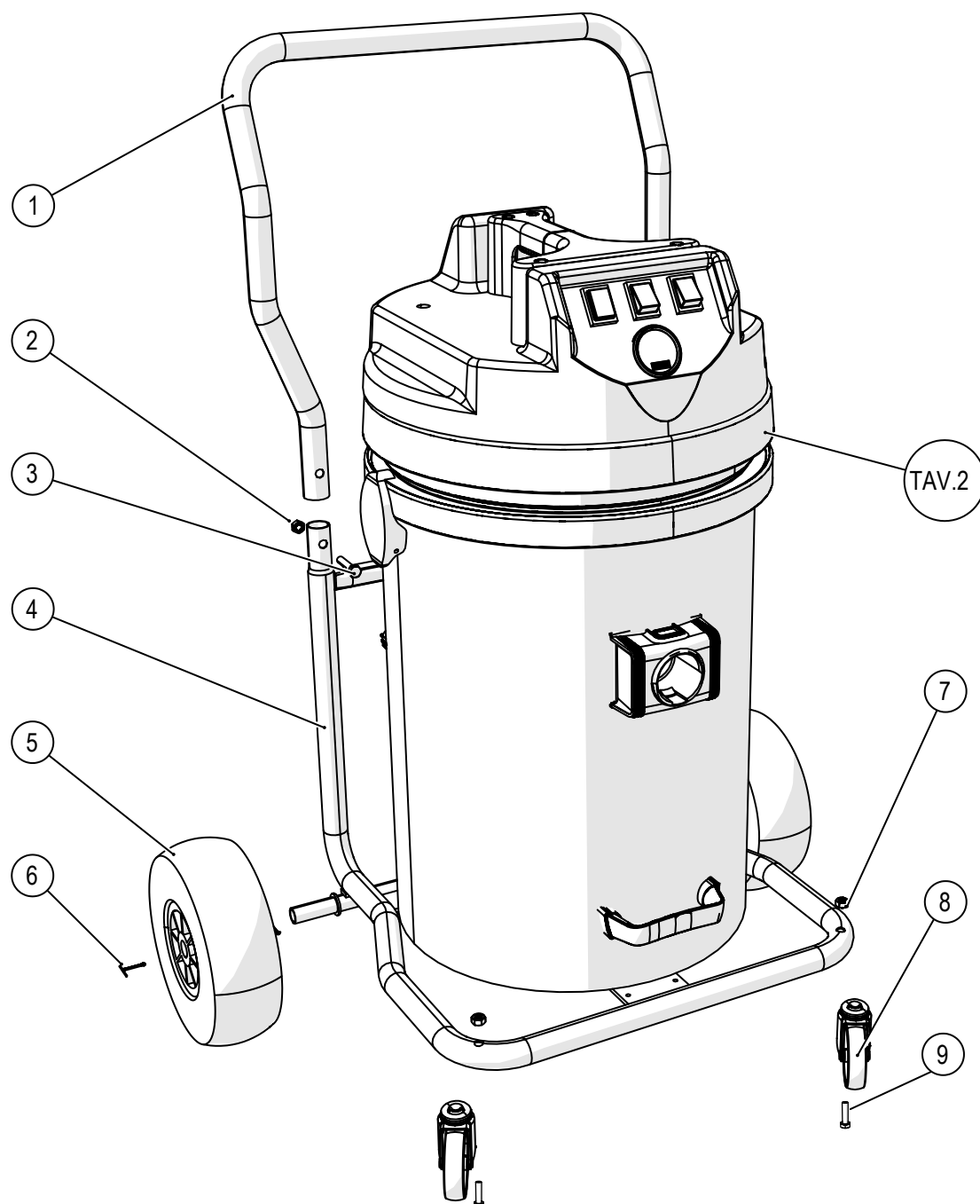

MAXI 80

METAL TROLLEY

Pos.	Cod.	Q.ty	Description
1	VTVS8150	1	METAL TROLLEY (PART A)
2	VTVS8151	2	CLOSED LOCK NUT M10
3	VTVS8152	2	HEXAGONAL HEAD METRIC SCREW M10X40
4	VTVS8153	1	METAL TROLLEY (PART B)
5	WHEELION	2	WHEEL Ø260MM
6	VTVS8154	2	STAINLESS STEEL PIN Ø29X40MM
7	VTVS8151	2	CLOSED LOCK NUT M10
8	VTVS8155	2	WHEEL Ø100MM
9	VTVS8156	2	HEXAGONAL HEAD METRIC SCREW M10X20

MAXI 80

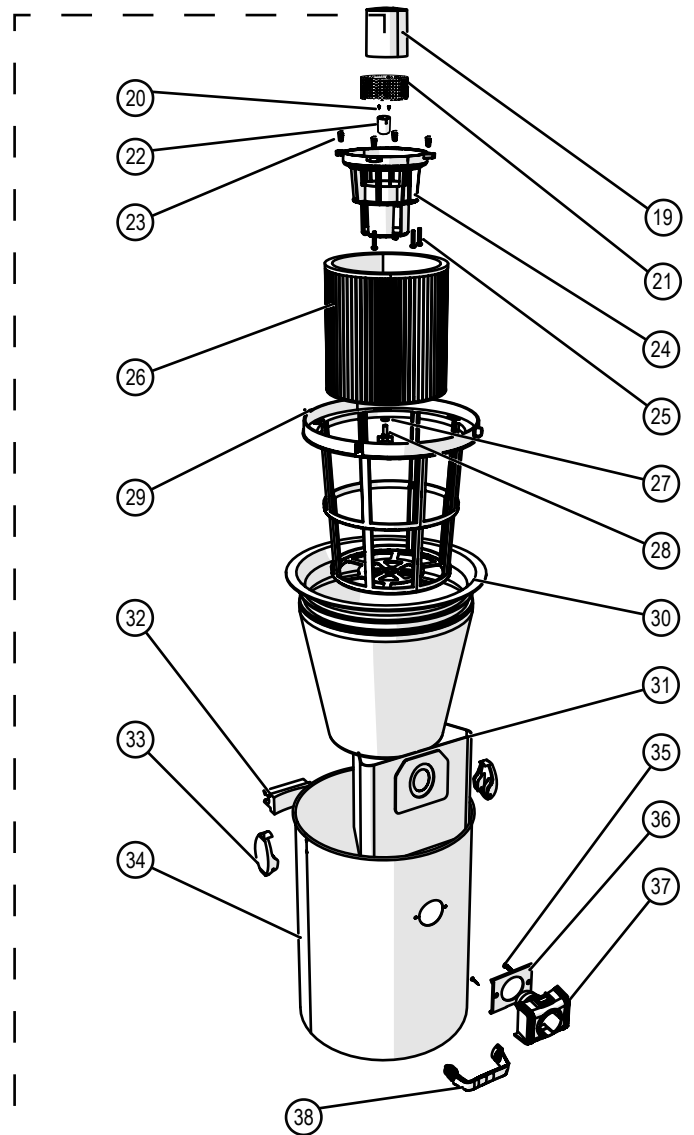
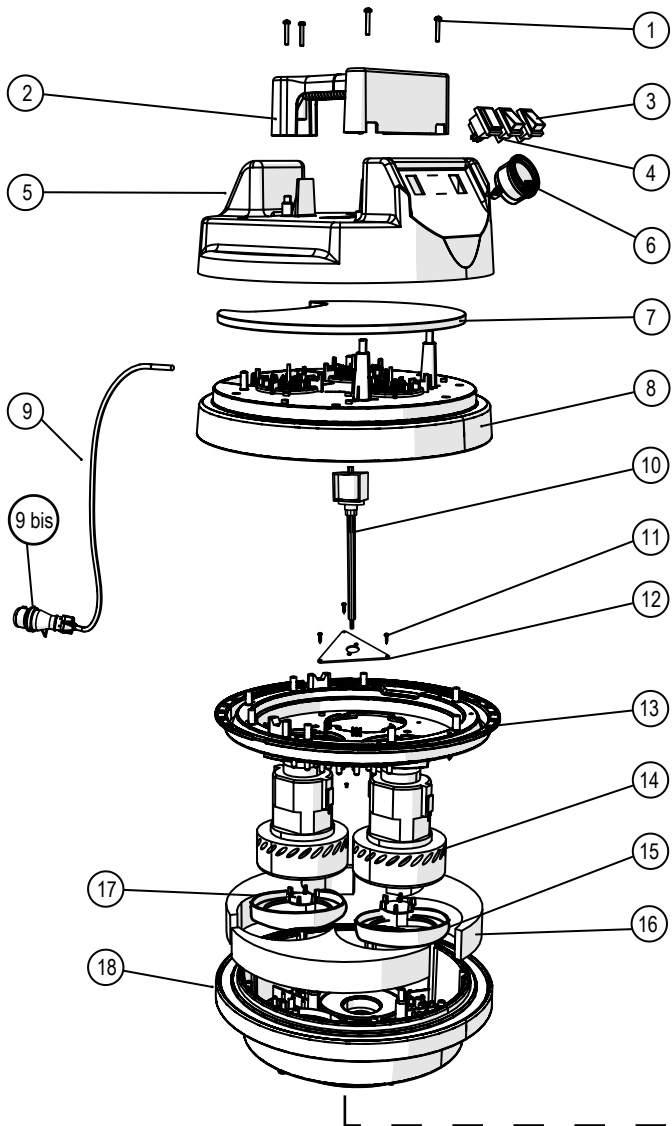

MAXI 80

HEAD

Pos.	Cod.	Q.ty	Description
1	VTVS7513	4	SELF TIPPING SCREW 5X30 ZN
2	VTVS8100	1	HANDLE E.2 L=229MM
3	VTVS7422Y	2	RED LIGHT SWITCH 2P
4	VTVS7525	1	BLACK SWITCH FOR FILTER SHAKER
5	VTVS8101	1	BLACK COVER Ø440 WITH 3 HOLES AND VACUUM GAUGE HOLE
6	VTVS8103	1	VACUUM GAUGE Ø50MM
7	VTVS8104	1	FOAM NOISE Ø370 E.2
8	VTVS8105	1	BLACK MOTOR COVER Ø452
9a	I10. 1505C- 110V Cord + Plug	1	POWER CORD H05 2X1,5MMQ 110V
9b	I10. 1605C- 240V Cord + Plug		
10	VTVS8106	1	SOLENOID VIBRATOR
11	VTVS7518	3	METRIC SCREW M4X14
12	VTVS8107	1	PLATE FOR VIBRATOR
13	VTVS8108	1	BLACK MOTOR HOLDER Ø444
14	a. VTVS 7826 - 110V Motor b. VTVS 7825 - 240V Motor	2	DOUBLE STAGE MOTOR
15	VTVS8109	2	"L"GASKET S/F H=8
16	VTVS8110	3	SOUND ASSORBENT TRIANGLE
17	VTVS8111	2	AUTOMATIC VALVE Ø50
18	VTVS8112	1	YELLOW MOTOR BASE Ø452 WITH HOLE FO VBR
19	VTVS8113	1	FLOAT Ø80
20	VTVS8114	2	SELF TIPPING SCREW 2.9X19 ZB
21	VTVS8115	1	METAL GRID Ø92MM H54MM
22	VTVS8116	1	VIBRATOR SPACER H30MM
23	VTVS8117	4	SPRING H12MM
24	VTVS8118	1	FLOAT SUPPORTING Ø168
25	VTVS7512	4	SELF TIPPING SCREW5X25 TC ZN
26	VTVS8022	1	HEPA CARTRIDGE FILTER Ø250 H178
27	VTVS8119	1	GASKET NBR 15X7, 8X2 MM
28	VTVS8120	1	CARTRIDGE WINGNUT M8X20
29	VTVS8121	1	FILTER BASKET Ø252
30	VTVS8021	1	POLYESTER FILTER WITH RING Ø44 (OPTIONAL)
31	VTVS055	5	POLYESTER BAG
32	VTVS8122	1	TANK ROLLO HINGE Ø25

MAXI 80

HEAD

Pos.	Cod.	Q.ty	Description
33	VTVS7491	2	COMPLETE SPRING HOOK BLACK
34	VTVS8124	1	STAINLESS STEEL TANK H=580
35	VTVS7512	2	SELF TIPPING SCREW 5X25 TCZN
36	VTVS7164	1	GASKET INLET Ø48
37	VTVS7165m	1	INLET Ø48
38	VTVS8125	1	COMPLETE HANDLE 120MM